

Product Picture

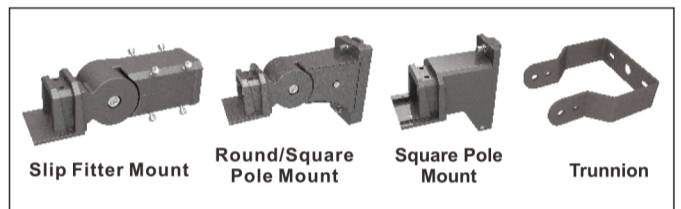
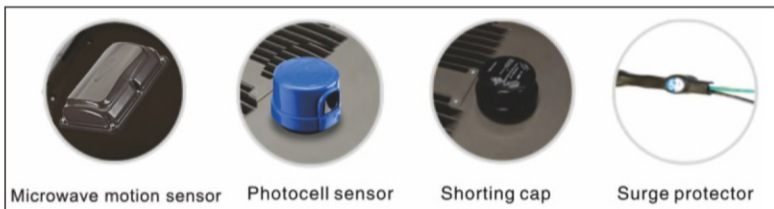
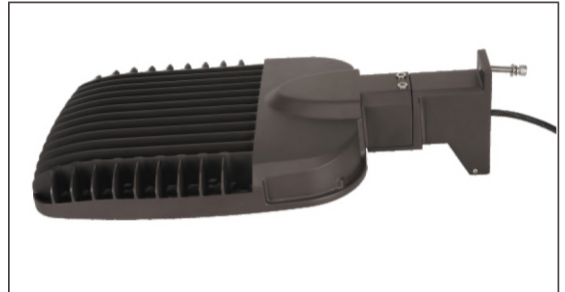
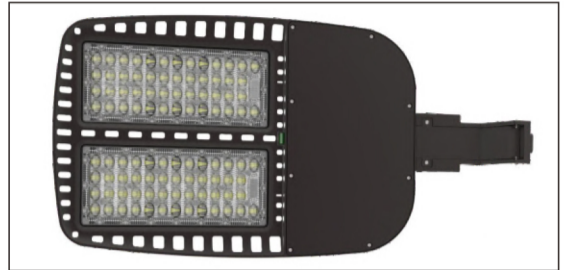

Microwave Motion Sensor

- Automatic switching or dimming when used in combination with 1–10V dimmable LED drivers or ballasts.
- Built-in daylight sensor.
- 1–10V interface can match up with Merrytek stand-alone daylight sensor MS01 and achieve daylight harvesting.
- Compact size makes it suitable to fix within most luminaires.
- Detection area, time delay and daylight threshold can be precisely set via DIP switch.
- Wide detection area, range up to 16m in diameter.
- Support higher mounting height 15m Max.
- Optional surface mounting and base mounting

The MC601V innovative and active motion detectors with HF system 5.8GHz. Motion can be detected through plastic, glass and thin non-metal materials.

The sensors allow energy saving without compromising comfort. When used in combination with 1–10V dimmable LED drivers or ballasts, they can achieve 3-step dimming function, which is perfect for use in some areas that requires a light change notice before totally switch off.

Also, the 1–10V interface in the sensors can match up with Merrytek stand-alone daylight sensor MS01, and implement daylight harvesting, means the lighting system has automated controls that either turn off or dim artificial light in response to the available daylight in the space.

As it uses the third generation Merrytek technology, normal 5.8GHz microwave module can easily reach high mounting high up to 15m and long detection area 10m in radius.

Product Features

- 1 European and American design style, high quality aluminum die casting, DUPONT powder painting process, round shape design, never fade, anti-cracking.
- 2 Adopt aerodynamic design, take heat away quickly, keep low temperature for heat sink and LED chip for longer lifespan and higher light efficiency.
- 3 A variety of installation ways, suitable for round pole, square pole, wall, ground and so on. All the screws are SUS316 stainless steel screws with stronger corrosion resistance ability.
- 4 SMD3030 led chip, high CRI, light efficiency up to 140lm/w, low light decay and long lifespan.
- 5 SOSEN high efficiency series 12KV anti-surge LED driver, installed on die casting cover of led driver, take heat away quickly to keep lower temperature and longer lifespan.
- 6 Through various of experimental tests: wind resistance level test, conduction radiation, 1.5G seismic test, UV aging test, drop, stacking test etc.
- 7 Easy to install, save labor 50%.

Product Applications

LED Shoebox/Area Light series can be widely used in Parking lot, Urban roads, Industrial areas, Residential areas, Sidewalks, Schools, Gardens and etc.



Los Angeles Port
— LED Shoebox light replacement

Long Beach Port
— LED Shoebox light replacement

Specifications

Size:MM

Structure Features

Shell materials: Aluminum & PC.
Finish: Dark Bronze/White

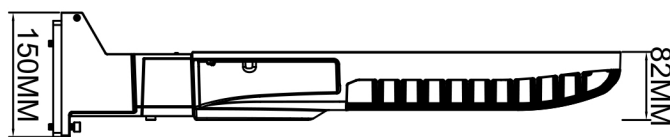
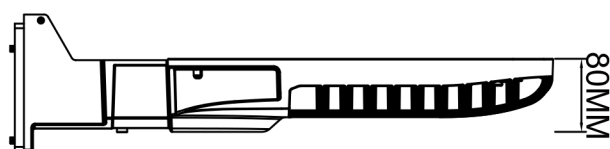
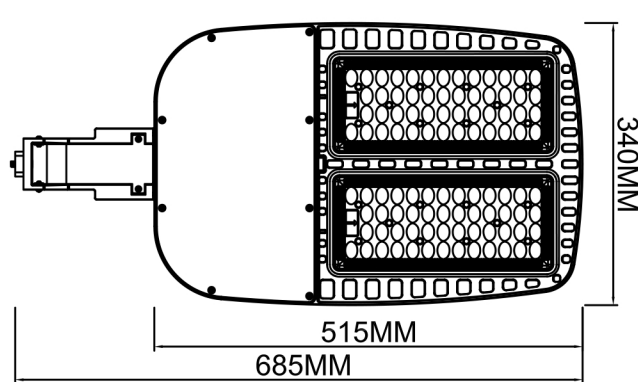
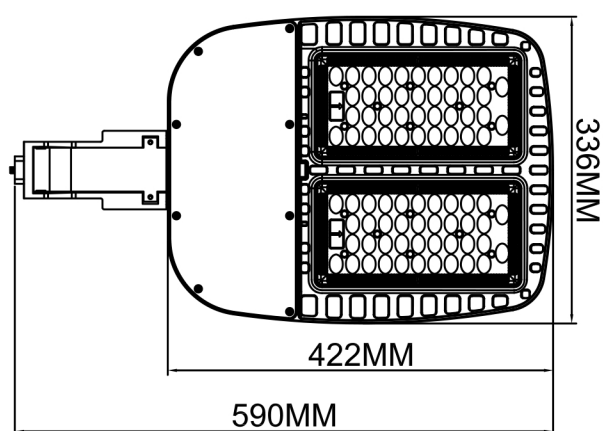

Power:60W/100W/150W/200W
Light Size:L422*W336*H80MM

Power:240W/300W/330W
Light Size:L515*W340*H82MM

Technical Parameters

Model	Power	Materials	Light Efficiency	Input Voltage	Power Factor	Luminous Flux	CRI	Beam Angle	IP Rate	Dimension
HG-SL-60WX-XXXX-A	60W	Die Casting Aluminum	>130Lm/W	AC100-277V AC200-480V	>0.95	7800-8400lm	80	TYPE3	IP65	422*336*80MM
HG-SL-80WX-XXXX-A	80W	Die Casting Aluminum	>130Lm/W	AC100-277V AC200-480V	>0.95	10400-11200lm	80	TYPE3	IP65	422*336*80MM
HG-SL-100WX-XXXX-A	100W	Die Casting Aluminum	>130Lm/W	AC100-277V AC200-480V	>0.95	13000-14000lm	80	TYPE3	IP65	422*336*80MM
HG-SL-120WX-XXXX-A	120W	Die Casting Aluminum	>130Lm/W	AC100-277V AC200-480V	>0.95	15600-16800lm	80	TYPE3	IP65	422*336*80MM
HG-SL-150WX-XXXX-A	150W	Die Casting Aluminum	>130Lm/W	AC100-277V AC200-480V	>0.95	19500-21000lm	80	TYPE3	IP65	422*336*80MM
HG-SL-200WX-XXXX-A	200W	Die Casting Aluminum	>130Lm/W	AC100-277V AC200-480V	>0.95	26000-28000lm	80	TYPE3	IP65	422*336*80MM
HG-SL-240WX-XXXX-A	240W	Die Casting Aluminum	>130Lm/W	AC100-277V AC200-480V	>0.95	31200-33600lm	80	TYPE3	IP65	515*340*82MM
HG-SL-300WX-XXXX-A	300W	Die Casting Aluminum	>130Lm/W	AC100-277V AC200-480V	>0.95	39000-42000lm	80	TYPE3	IP65	515*340*82MM
HG-SL-330WX-XXXX-A	330W	Die Casting Aluminum	>130Lm/W	AC100-277V AC200-480V	>0.95	42900-46200lm	80	TYPE3	IP65	515*340*82MM

Photometry

TYPE3

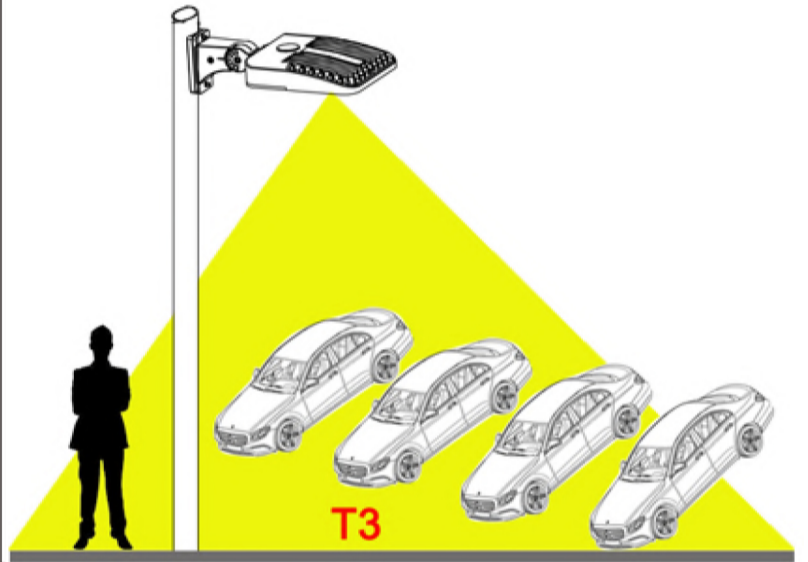
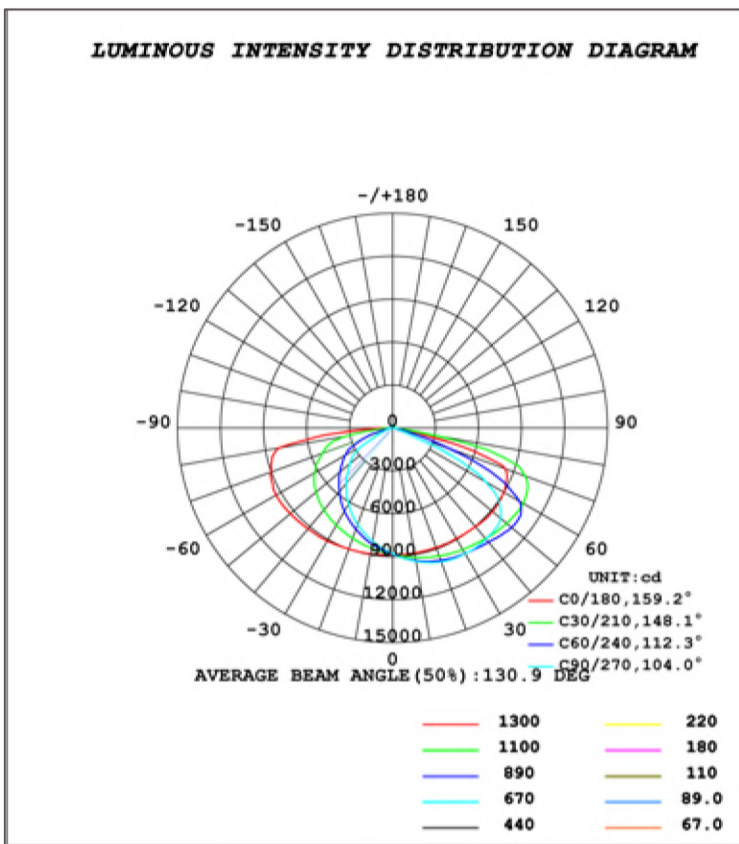

Packing

60W-200W:

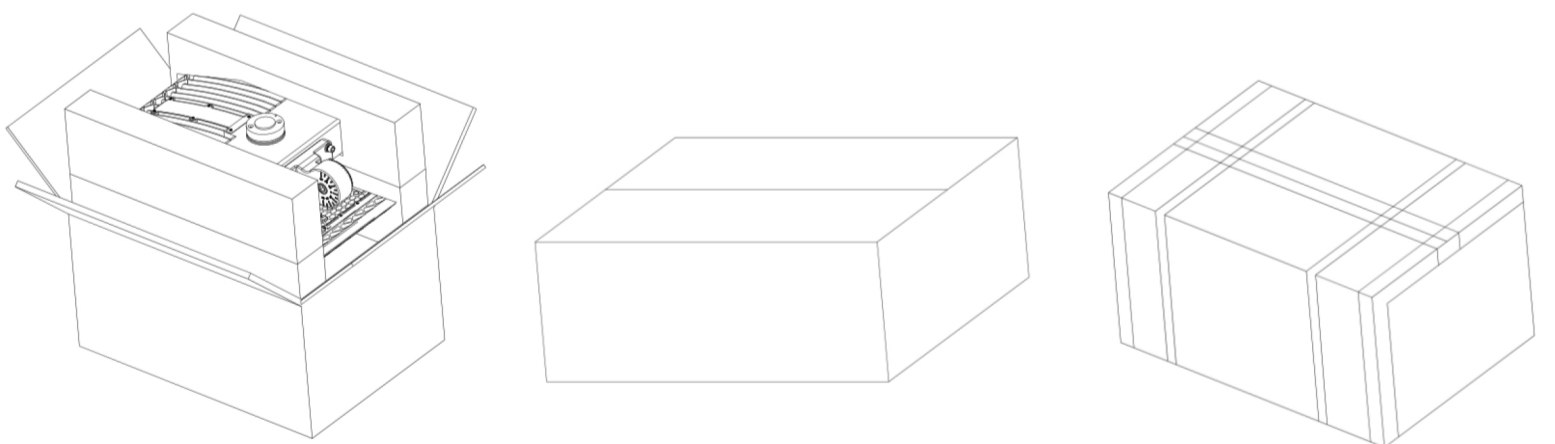

240W-330W:

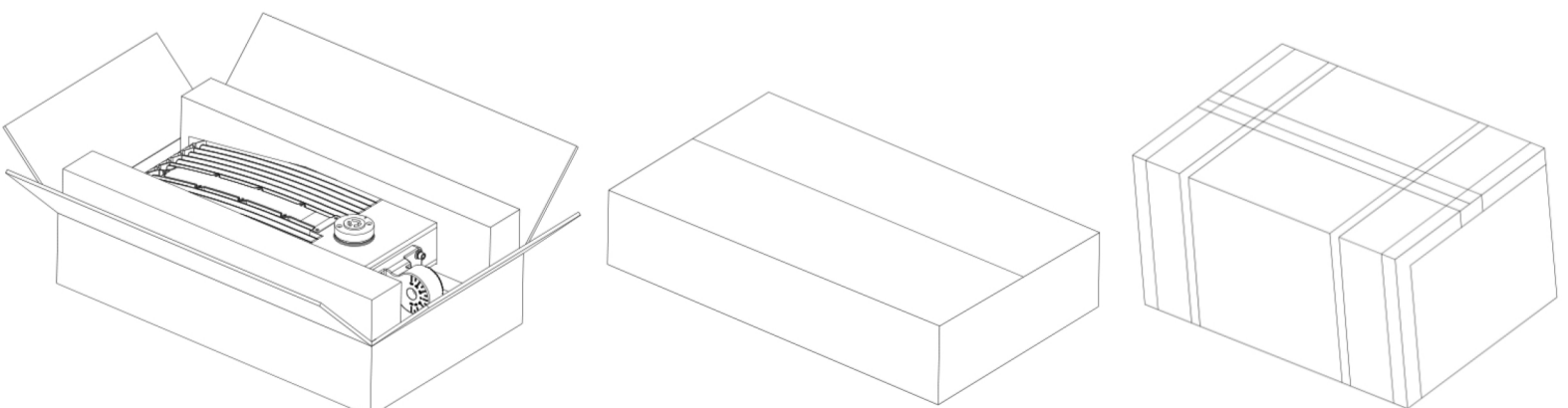

The Installation Diagram

1.Slip Fitter Mount(Adjustable Angle:-90° ~+90°)

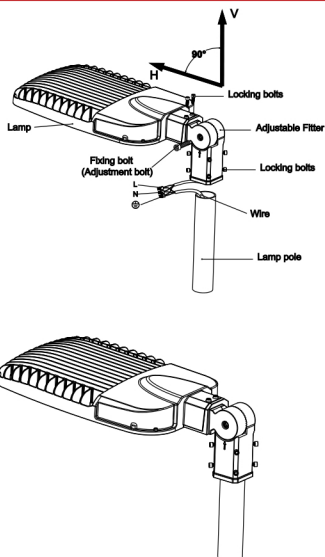

4.Square Pole Mount(Adjustable Angle:-90° ~+90°)

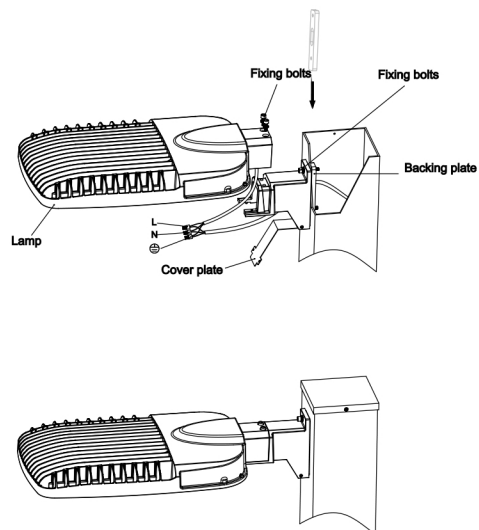

2.Adjustable Square(Adjustable Angle:-90° ~+90°)

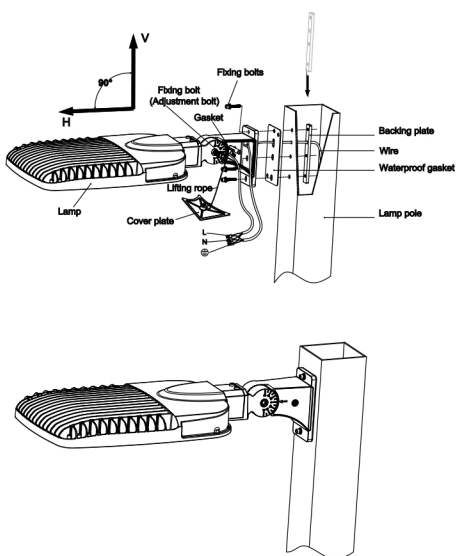

5.Trunnion (Adjustable Angle : -90° ~+90°)

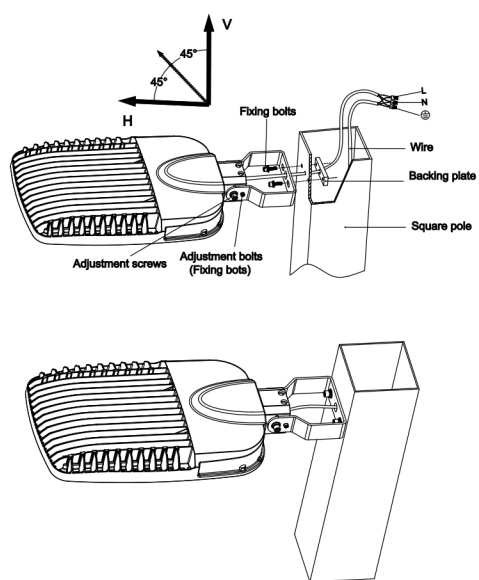

3.Round Pole Mount(Adjustable Angle:-90° ~+90°)

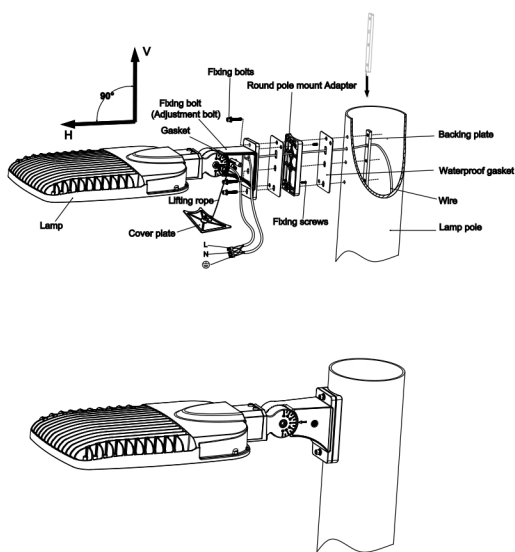

6.Wall Mount(Adjustable Angle:-90° ~+90°)

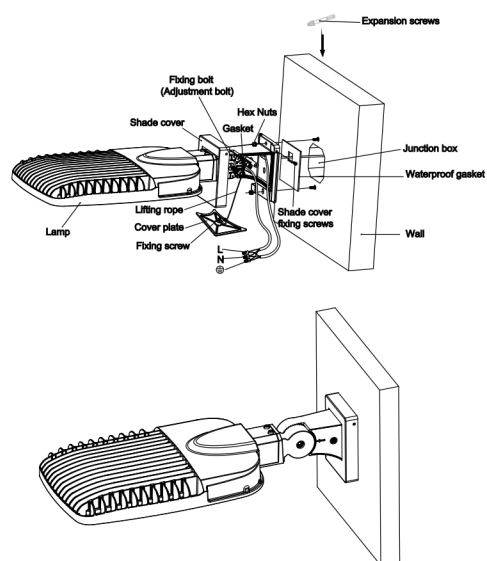

Notice For User

- 1、 Read the installation instructions before install the luminaire.
- 2、 The input voltage and lamps should be matched, after connecting the power line , please make sure the wiring section is insulated.
- 3、 No-professionals, must not install and disassemble the lamps.